

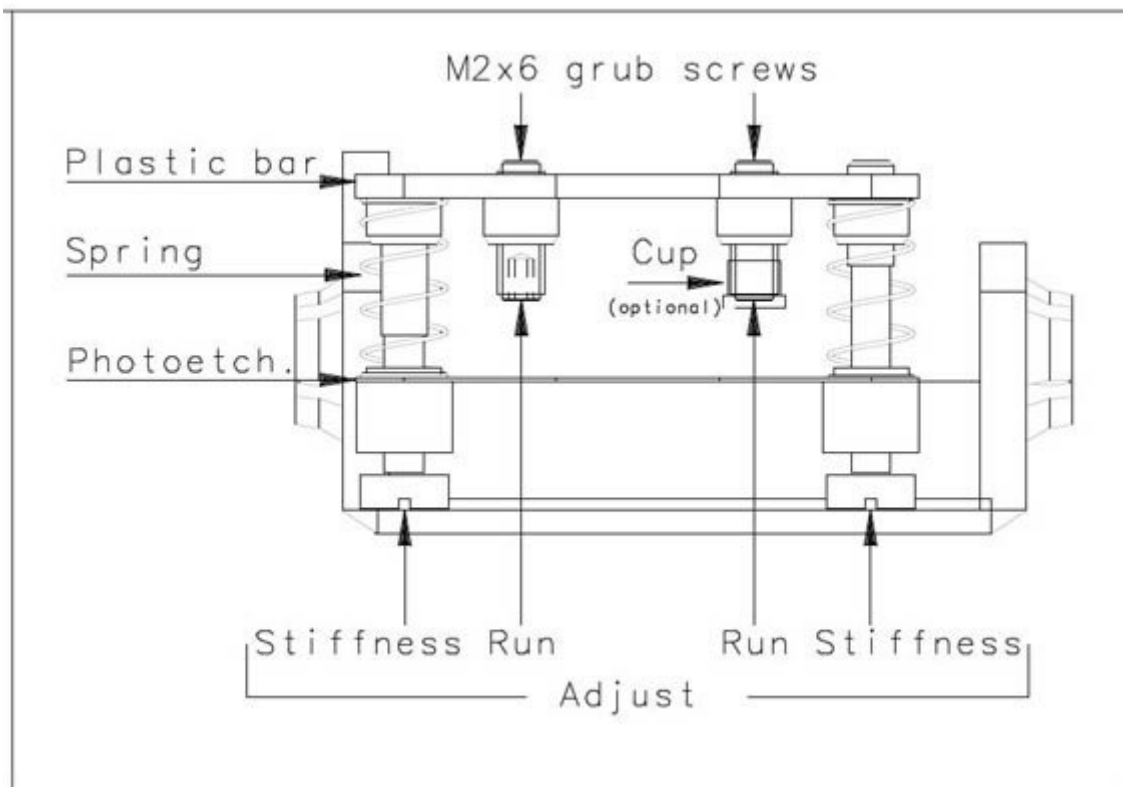

How to assemble the spring suspension in a Slot.it model

This document applies to the Slot.it spring suspension, code CH47.

The spring suspension consists of two brass screws, two springs, one photoetched base part, one plastic top bar, two grub screws and some plastic cups.



Once assembled inside the car, both the stiffness of the springs and the length of the run of the suspensions can be adjusted without removing the chassis.

The first step is optional and it is about assembling the grub screw and the plastic cup. The purpose of the cup is to act as a stopper for the grub screw when the grub screw hits the photoetched plate to limit the run of the suspension, but experience has shown that the cup can be safely omitted. If you still want to use the cups, make sure to insert the hexagonal hole side of the grub screw in the cup, not the flat part. It is better to do so with a vice.

Next, insert an Allen key in the grub screw, and screw it in the plastic bar.

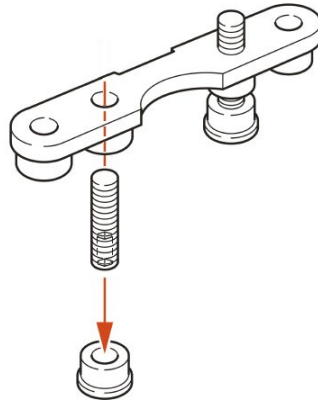

Now take the brass screws and put them in place:

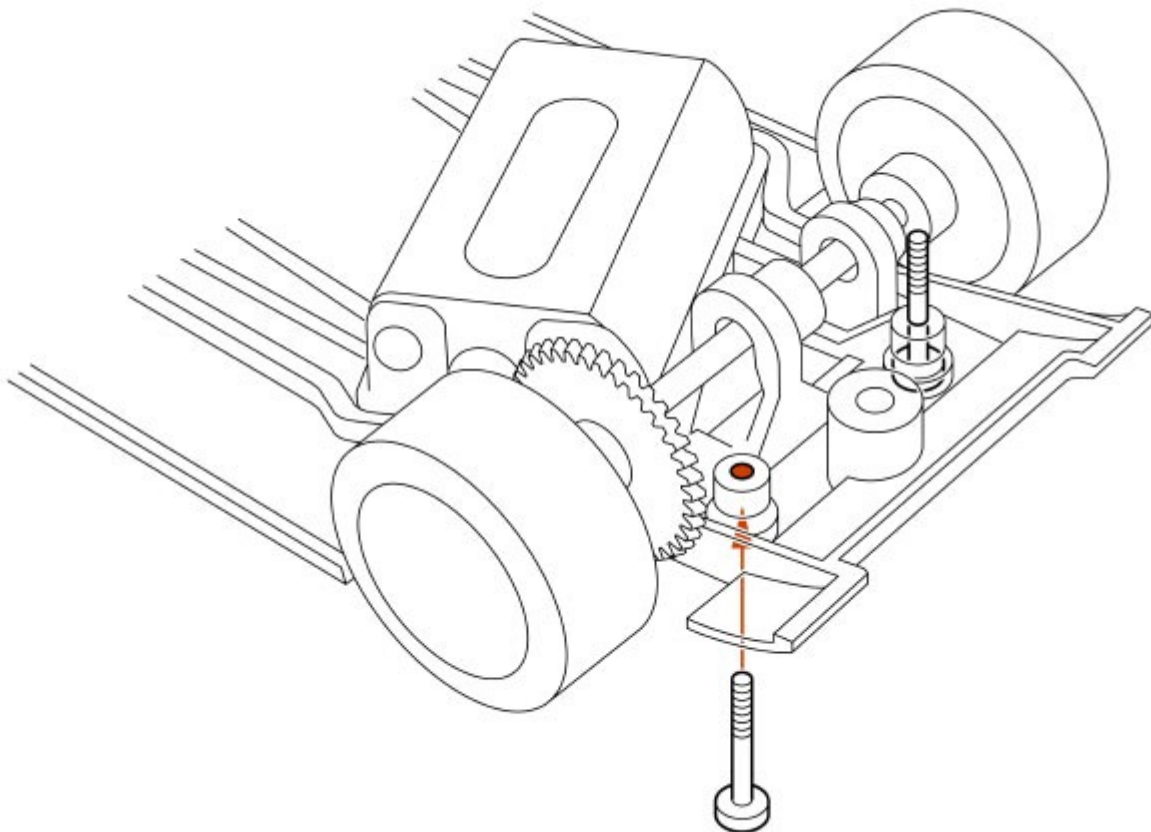

It is now the turn of the photoetched plate. It will be necessary to screw the brass screws through the plate because its holes are very precise. Note please that the plate has thicker circles around the external holes: these are made to keep the spring in place, so make sure they are facing up.

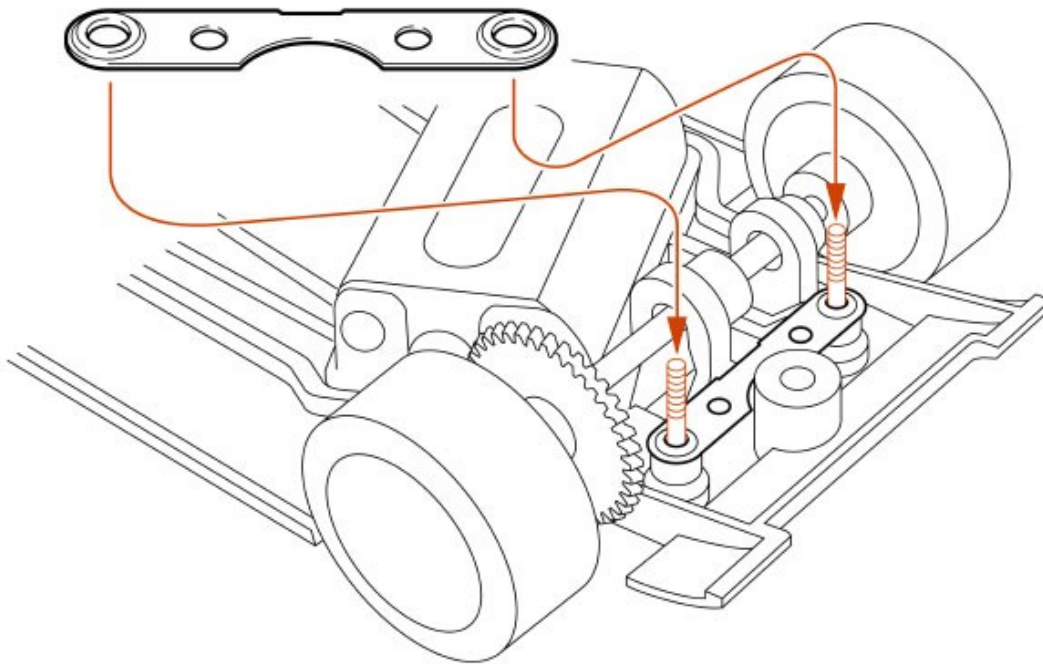

Now it is time to put the spring in place, and to top everything with the plastic bar which was previously assembled.

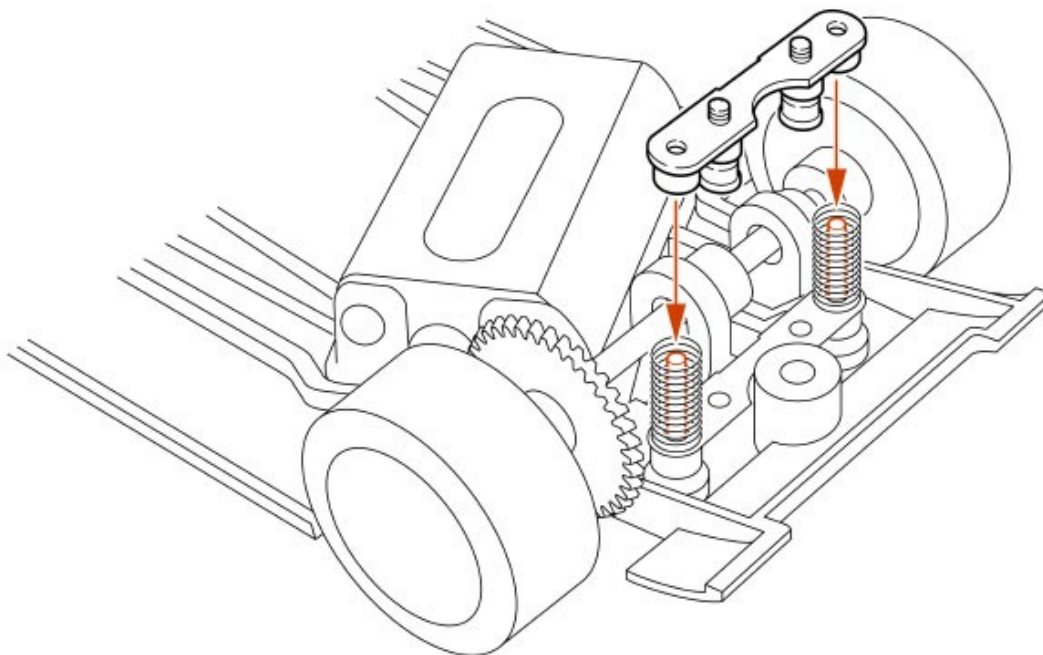

Now everything is ready:

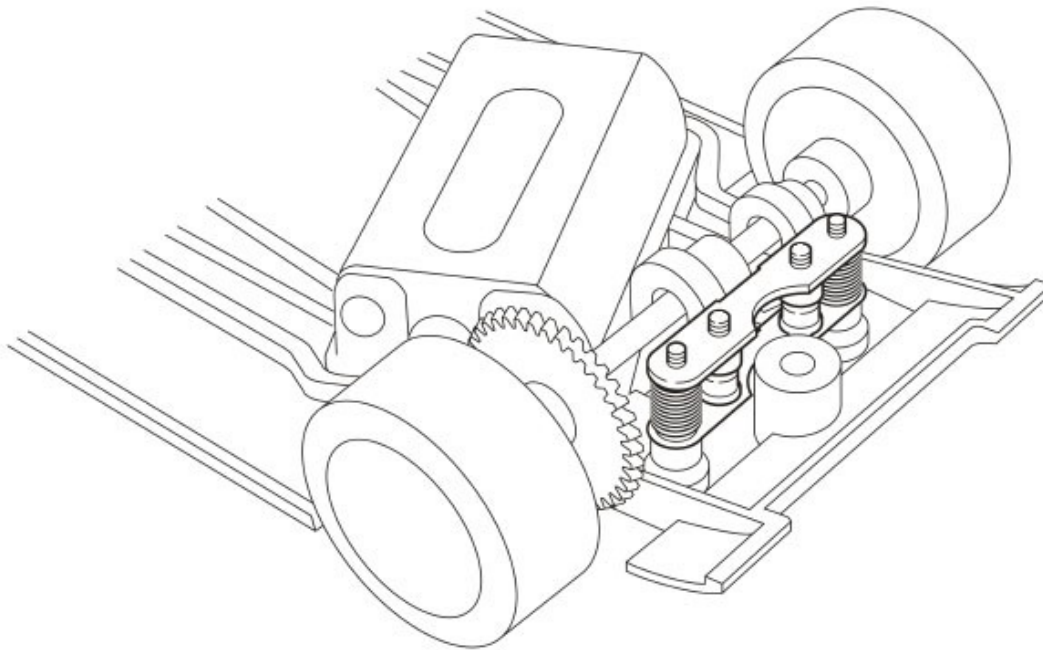

Remember: once you have the suspension installed, both the stiffness of the springs and the length of the run of the suspensions can be adjusted without removing the chassis: the stiffness, by adjusting the brass screws, and the run length, by adjusting the position of the grub screw. To this avail, the latest generation of Slot.it chassis provides a small hole in the chassis in correspondence of the left grub screw, while the grub screw on the right can be reached from the semicircular opening left in the chassis for the inline crown.

Many thanks to Andrea Fortunato of Project Japan for the nice drawings.